

progettazione interna, costruzione, collaudo, assistenza.



		Sacchetti bocca aperta Bottom welded bags	Sacchetti shopper T-shirts
Nr. Piste Number of tracks	senza anima di cartone without carton core con anima di cartone with carton core	2-3 3	3 3
Larghezza minima sacco Min. bag width	senza anima di cartone without carton core con anima di cartone with carton core	150 mm 200 mm	220 mm 220 mm
Larghezza massima sacco Max. bag width	a 2 piste / 2 tracks a 3 piste / 2 tracks	420 mm 300 mm	- 270 mm
Lunghezza minima sacco Min. bag length		250 mm	450 mm
Lunghezza massima sacco Max. bag length		1500 mm	650 mm
Diametro massimo rotolo Max. roll diameter		110 mm	110 mm
Diametro interno anima di cartone Inner diameter of carton core		30 mm	30 mm
Spessore minimo film Min. film thickness	HDPE	0,010 mm	0,010 mm
Spessore massimo film Max. film thickness	LPDE	0,060 mm	0,030 mm
Velocità meccanica massima Max. mechanical speed		250 cycles/min	230 cycles/min
Velocità film massima Max. film speed		150 metres/min	150 metres/min
Potenza totale assorbita Total absorber power		16 Kw	20 Kw
Consumo aria compressa Compressed air consumption		500 lt/min	800 lt/min

Le illustrazioni e le caratteristiche tecniche del presente catalogo sono informative e non impegnative.
The illustrations and technical specifications in this catalogue are provided as general information and are not binding.

progettazione interna
Internal planning



Costruzione
Construction



Collaudo
Test



Assistenza
Customer service

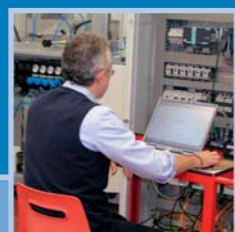

internal planning, construction, test, customer service



Mober

via Buonarroti 2, 21053 Castellanza (VA), ph. +39.0331.500407 R.A. - fax +39.0331.505207
www.mober.it - info@mober.it



0101011101000101110101011111010101000011101000101010101010101
01010111010100101
01010111010001010111010101111010101
01010111010001011101010111010101110101011
10001010111010101111010101
010101110101010010111010101
0101011101000101011101010111010101010111
1000101011101010111101010101
010101110101001101



serie

roller 110 SPH

serie

roller 110 SPH

DESIGN SERVICE 07

dal 1959 termosaldatrici automatiche per film plastici

since 1959 automatic bag-making machines for plastic film



010101110100010101110101111010101
1000101011101010111101010100101
01010111010001010111010101001011101000101010101010101
01010111010100101

- roller
- nastrosac
- gamma
- celta
- wrapp

110 SPH



Caricatore automatico anime di cartone.
Automatic loader of carton core.



OP 13:
Piegatore a "C".
"C" folding unit.

OP 3:
Apparecchiatura per sacchi
con stampa a registro.
Device for printed film.

OP 6:
Apparecchiatura per inserimento
raffa.
Device for the insertion of raffa.

Opzionali a richiesta
Optionals on demand

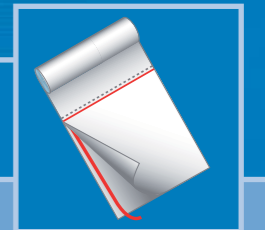
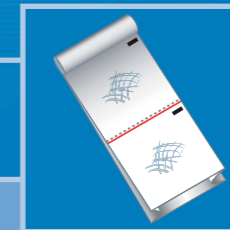
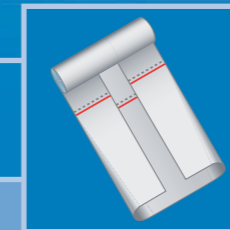

ITA Linea per la produzione in 2 o 3 piste di sacchi shopper e sacchi a bocca aperta in rotolo con pretaglio per lo strappo. Confezione: in rotoli, con e senza anima di cartone, anche nastrati con fascetta di carta. Opzionale: dispositivo per sacchi stampati con tacca di stampa. Arrotolatore a 6 mandrini con caricatore automatico dell'anima di cartone.

GB Line for the production on 2 or 3 tracks of T-shirt and bottom welded bags on roll with precut to tear off. Packaging: in roll, with or without carton core, even paper taped. Optional: device for printed bags with print mark. Winding unit at 6 mandrels with automatic loader of carton core.

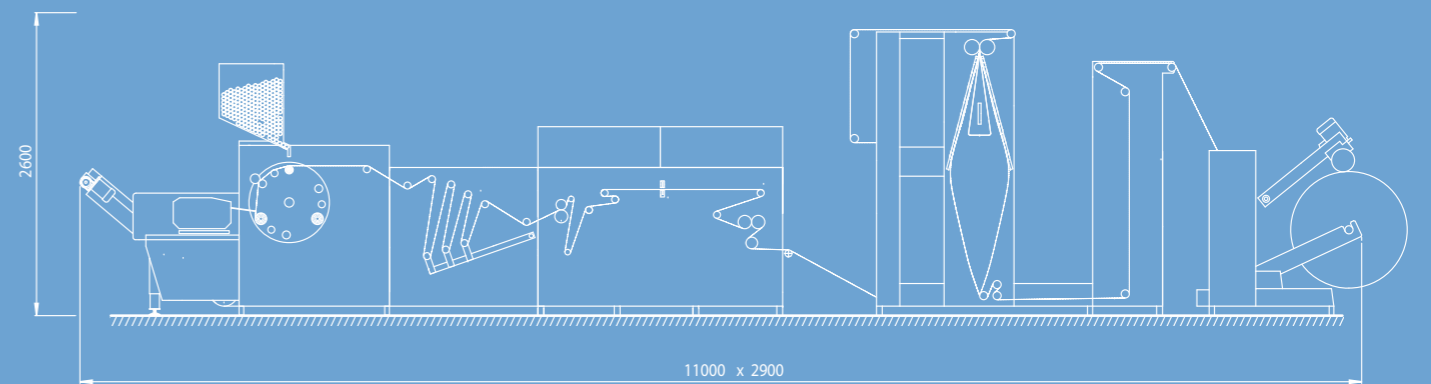
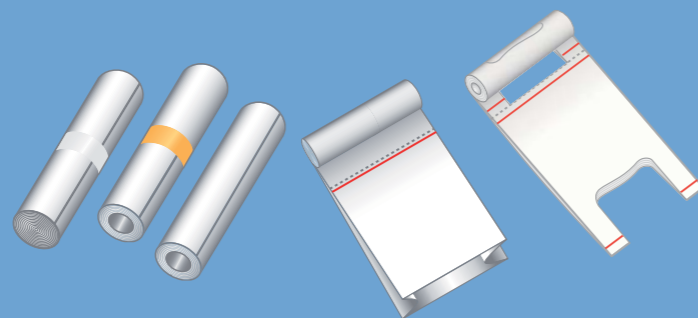

serie
roller 110 SPH