

dal 1959 termosaldatrici automatiche per film plastici

since 1959 automatic bag-making machines for plastic film



roller

130 E/CART

nastrosac

gamma

delta

wrapp



Caricatore automatico anime di cartone.
Automatic loader of carton core.



OP 13:
Piegatore a "C".
"C" folding unit.

OP 5:
Inserimento laccetti.
Device for the insertion of metal strip.

OP 3:
Apparecchiatura per sacchi con stampa a registro.
Device for printing film.

Opzionali a richiesta
Optionals on demand

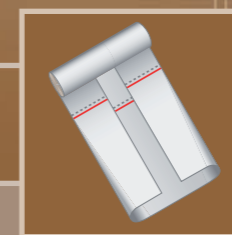

ITA Linea per la produzione in 2, 3 o 4 piste di sacchi a bocca aperta con pretaglio per lo strappo. Linea specifica per rotoli con e senza anima di cartone. Confezione: in rotoli nastrati con fascetta di carta. Speciale sistema movimentazione film anti stiramento saldature progettato per film anche molto sottili. Arrotolatore a 6 mandrini con caricatore automatico dell'anima di cartone.

GB Line for the production on 2, 3 or 4 tracks of pre-cut bottom welded bags for tearing. Special line for rolls with or without carton core. Packaging: rolls with paper tape. System of film movement anti stretch sealing projected even for very thin film. Winding unit with 6 mandrels and automatic loader of carton core.

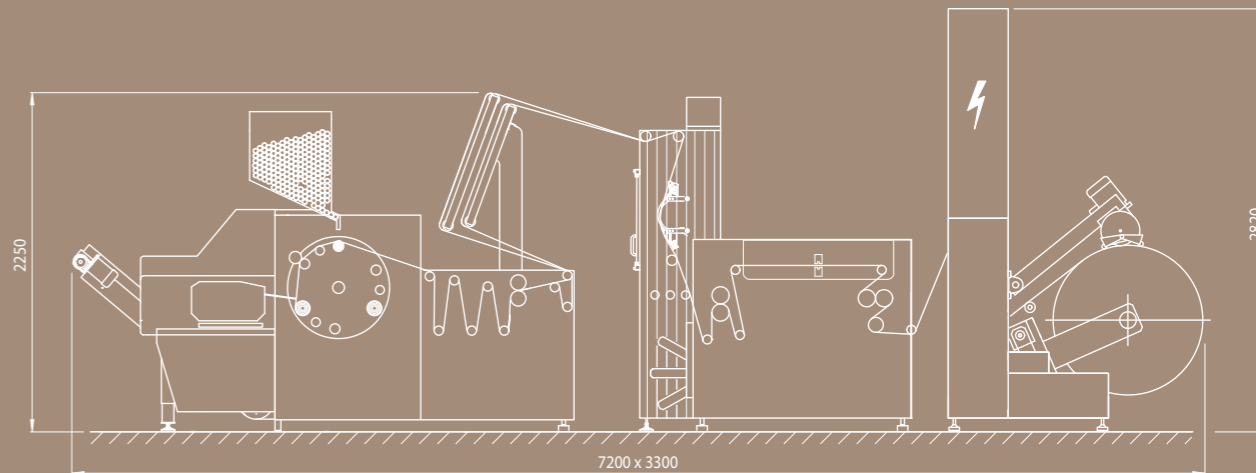
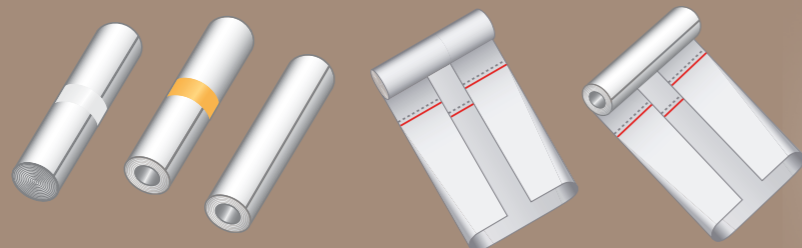

serie

roller 130 E/CART